

| Item | Name                     | Quantity |
|------|--------------------------|----------|
| 1    | Main Housing - Right     | 1        |
| 2    | Glue Pusher              | 1        |
| 3    | Glue Guide               | 1        |
| 4    | Guide Retainer           | 1        |
| 5    | Round Head Screw         | 6        |
| 6    | Glue Trigger             | 1        |
| 7    | Heating Element Assembly | 1        |
| 8    | Multi-Hole Nozzle        | 1        |

|  |                |          |        |                                   |            |
|--|----------------|----------|--------|-----------------------------------|------------|
| UNLESS OTHERWISE SPECIFIED, DIMENSIONS ARE IN INCHES |                | NAME     | DATE   | TITLE<br><b>GLUE GUN ASSEMBLY</b> |            |
| .XX = ±.01   | ANGULAR = ±    | DRAWN    | 1379   |                                   | 04/18/2026 |
| .XXX = ±.005   | FRACTIONAL = ± | CHECKED  |        |                                   |            |
| .XXXX = ±.000-                                       |                | APPROVED |        |                                   |            |
| SURFACE FINISH ✓                                     |                |          |        | SIZE<br><b>C</b>                  |            |
| DO NOT SCALE DRAWING                                 |                |          |        | DWG NO.<br><b>26-WAH</b>          |            |
| BREAK ALL SHARP EDGES AND REMOVE BURRS               |                |          |        | REV.                              |            |
| THIRD ANGLE PROJECTION                               |                | MATERIAL | FINISH | SCALE<br><b>1:1</b>               |            |
|  |                |          |        | WEIGHT                            |            |
|  |                |          |        | SHEET<br><b>1 of 3</b>            |            |

4

3

2

1

# PART 1: MAIN HOUSING - RIGHT

MATERIAL: ABS PLASTIC  
QUANTITY: 1  
VOLUME: 2.953534 in<sup>3</sup>

D

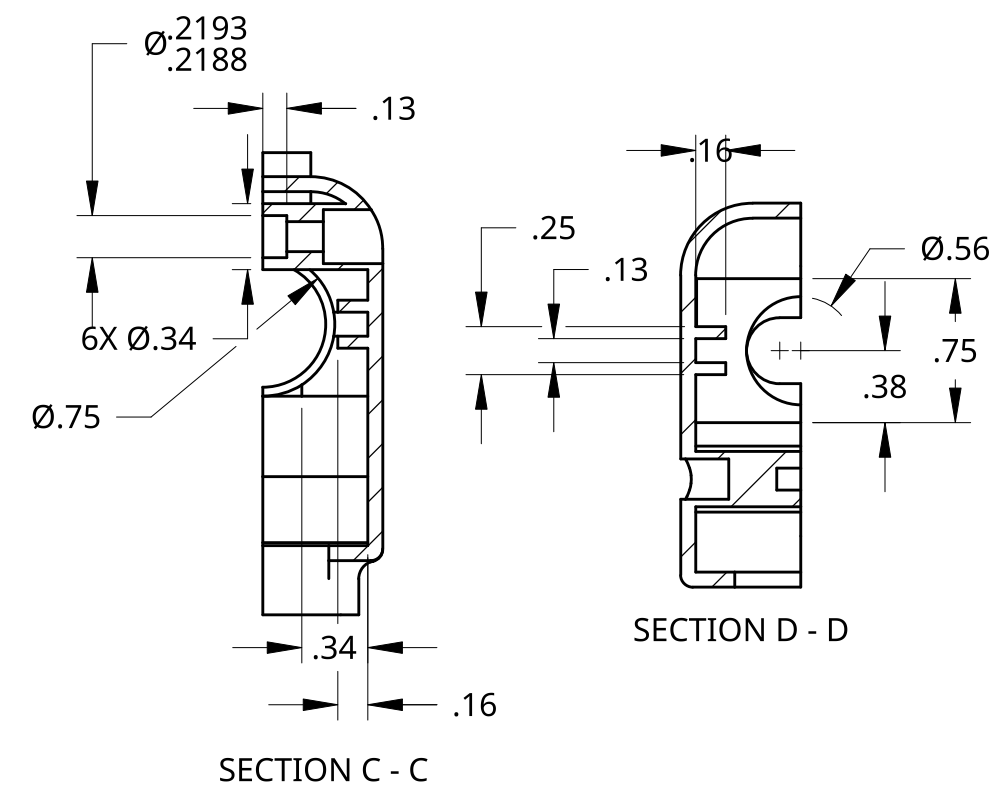
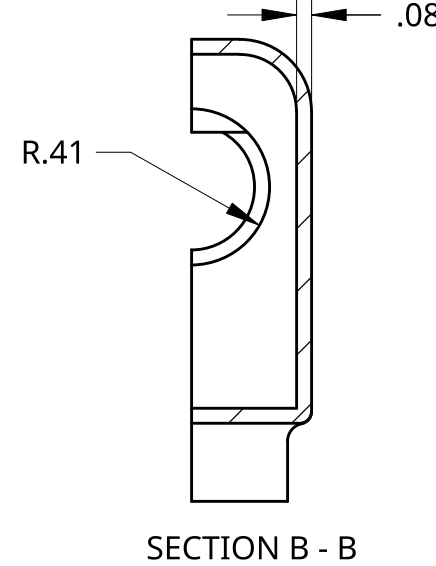
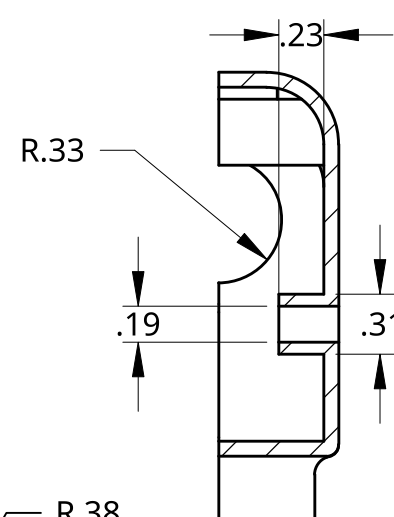
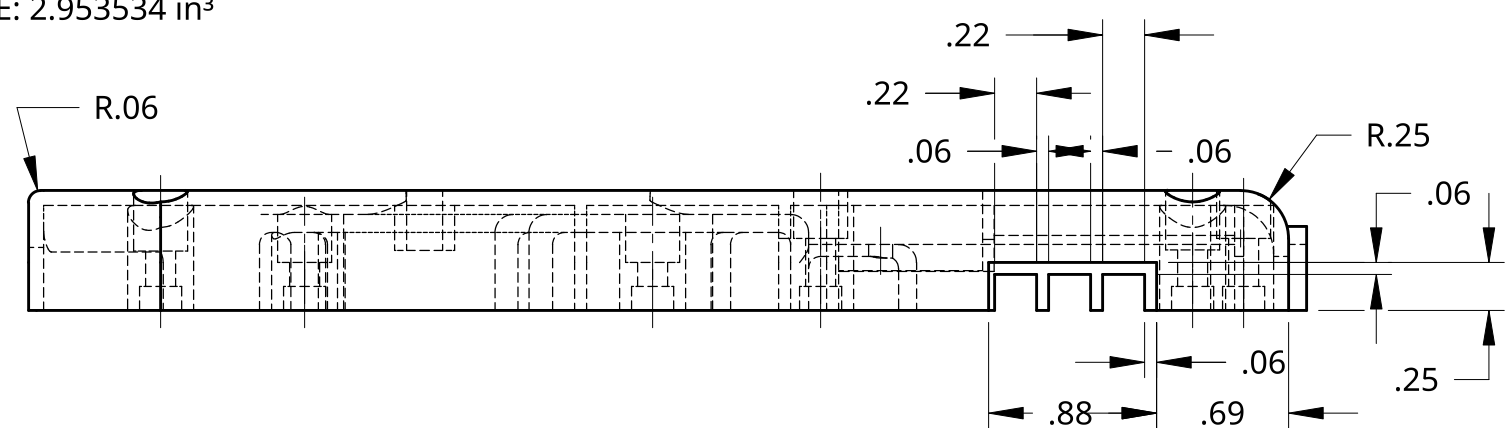

D

C

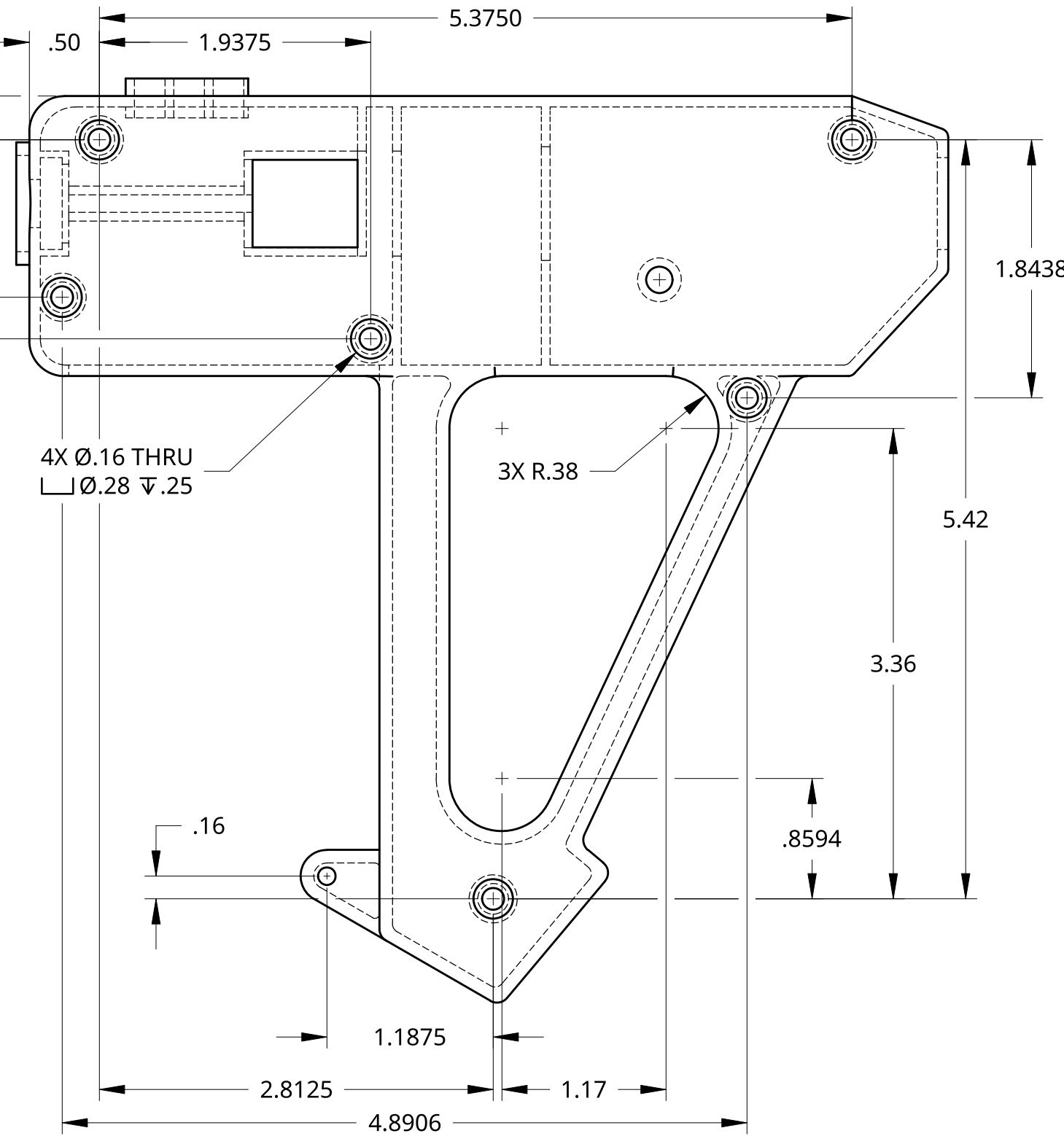
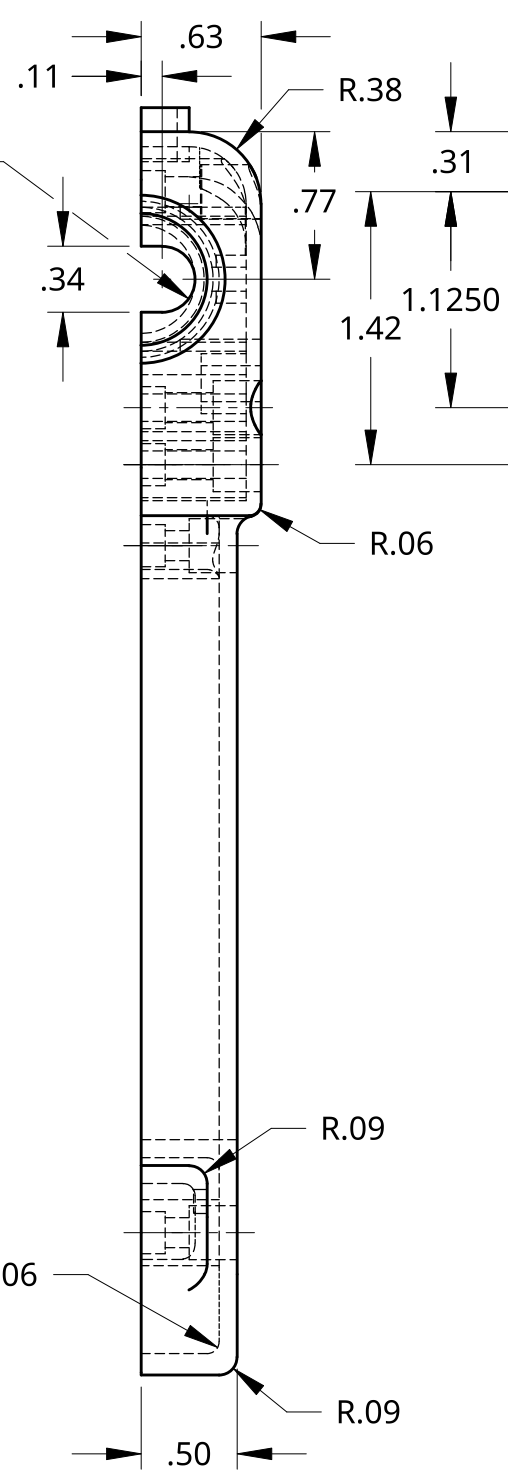
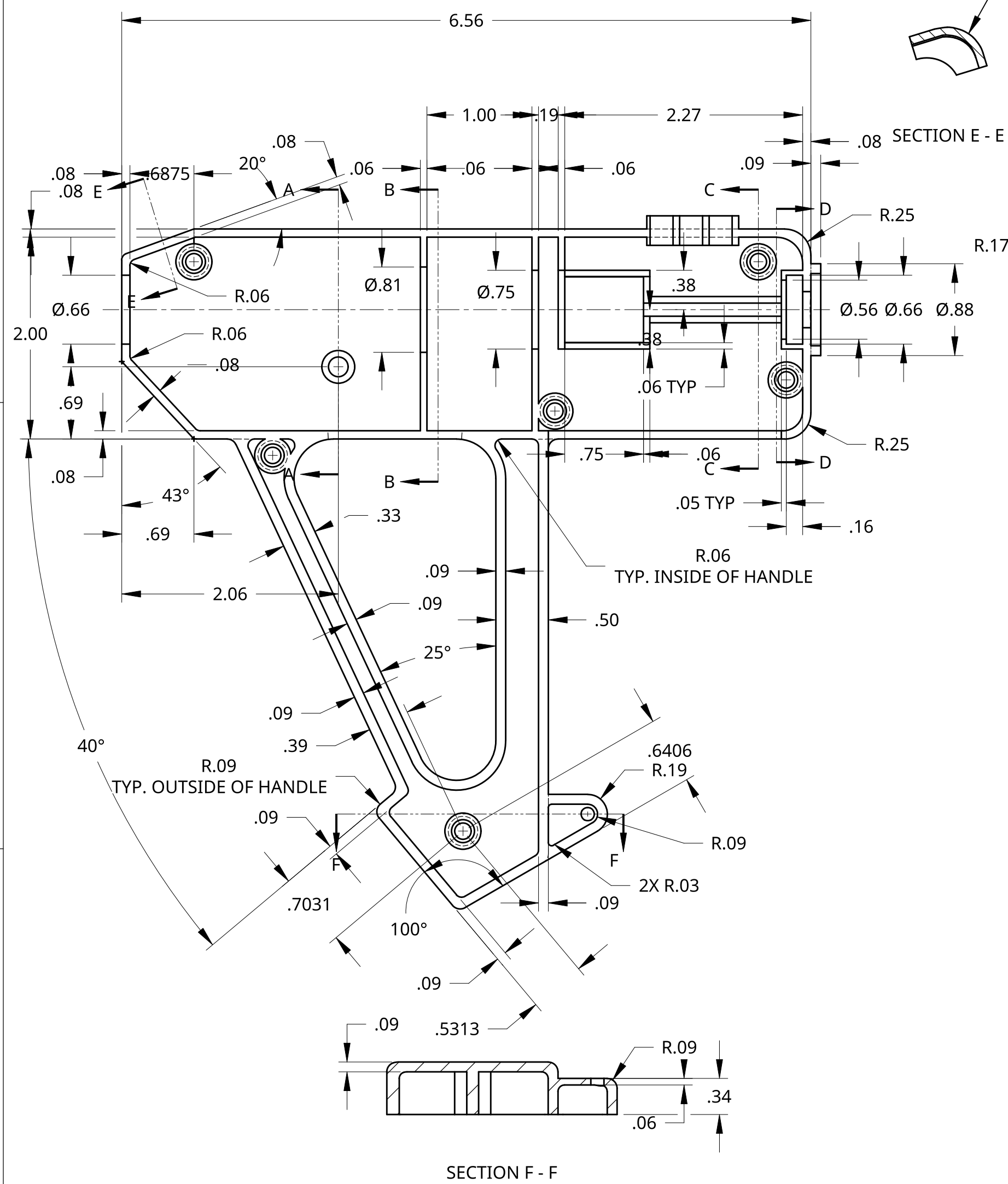

C

B

B

A

A

|  |          |            |                  |         |        |
|--|----------|------------|------------------|---------|--------|
| UNLESS OTHERWISE SPECIFIED, DIMENSIONS ARE IN INCHES<br>.XX = ±.01<br>.XXX = ±.005<br>.XXXX = ±.000- |          | NAME       | DATE             | TITLE   |        |
| DRAWN  | 1379     | 04/18/2026 | GLUE GUN DETAILS |         |        |
| CHECKED  |          |            | SIZE             | DWG NO. | REV.   |
| APPROVED   |          |            | C                | 26-WAH  |        |
| DO NOT SCALE DRAWING   | MATERIAL | FINISH     | SCALE            | WEIGHT  | SHEET  |
| BREAK ALL SHARP EDGES AND REMOVE BURRS   |          |            | 1:1              |         | 2 of 3 |
| THIRD ANGLE PROJECTION   |          |            |                  |         |        |

4

3

2

1

4

3

2

1

### PART 2: GLUE PUSHER

MATERIAL: ABS PLASTIC  
QUANTITY: 1  
VOLUME: 0.116491 in<sup>3</sup>

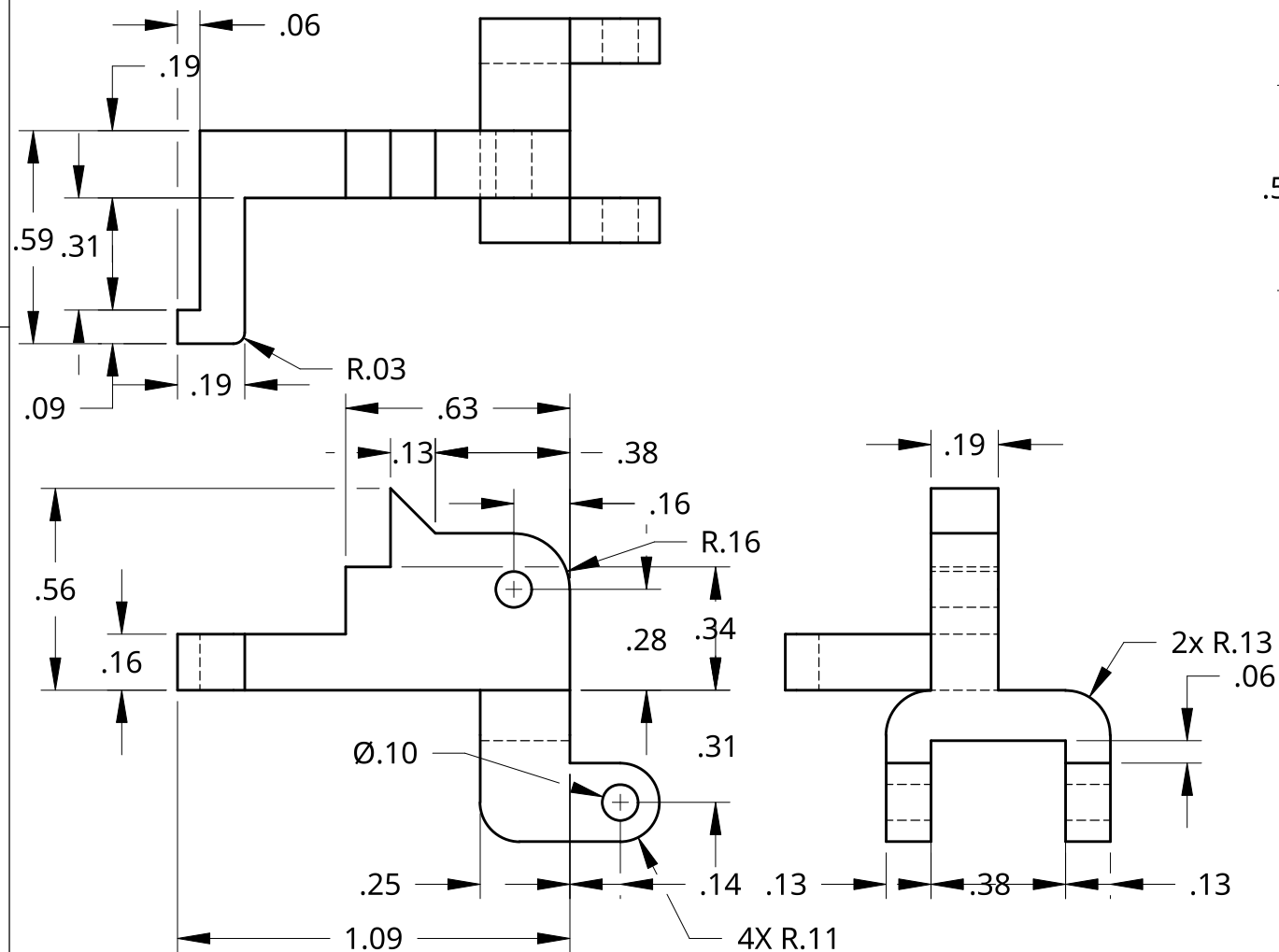

### PART 3: GLUE GUIDE

MATERIAL: ABS PLASTIC  
QUANTITY: 1  
VOLUME: 0.186378 in<sup>3</sup>

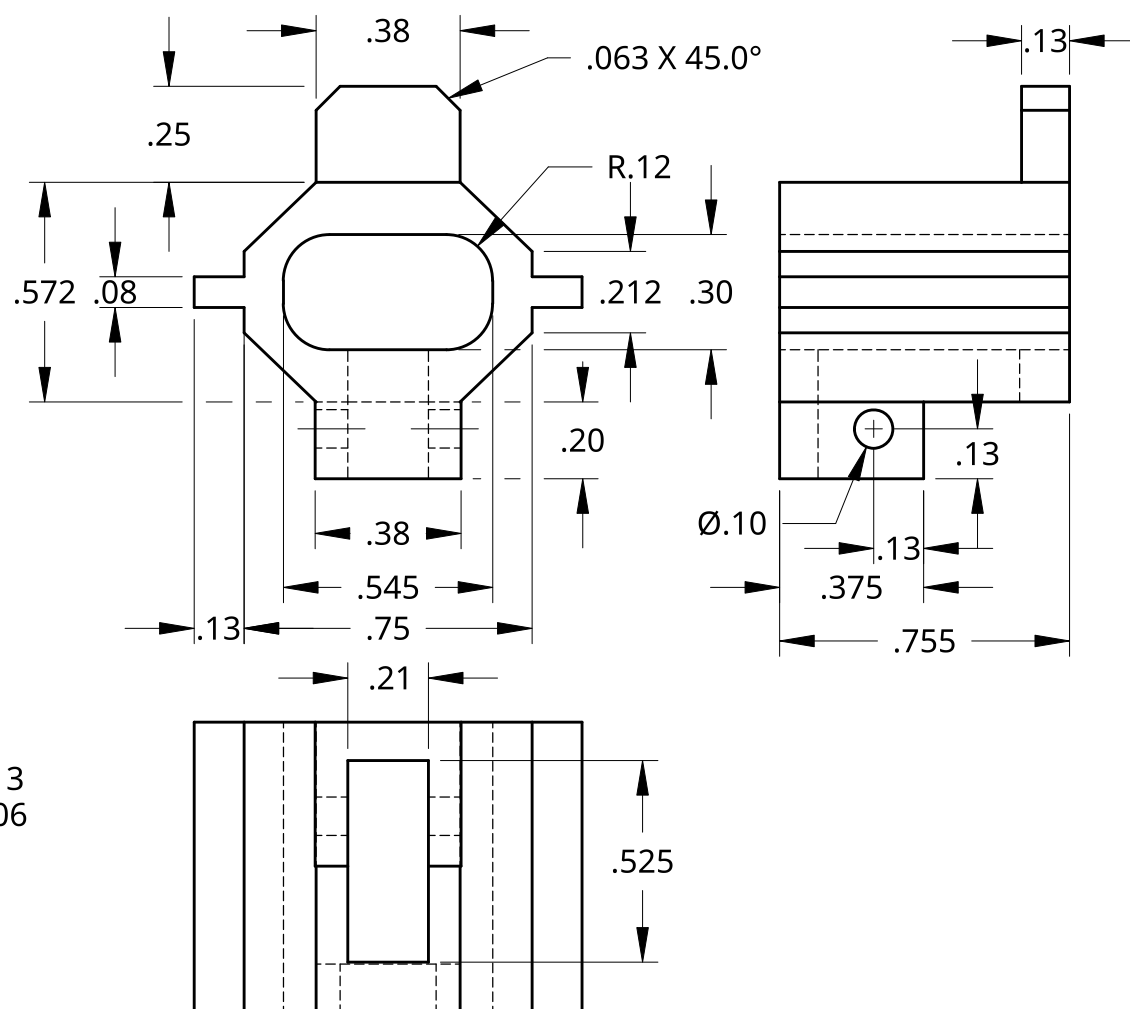

### PART 4: GUIDE RETAINER

MATERIAL: ABS PLASTIC  
QUANTITY: 1  
VOLUME: 0.04942 in<sup>3</sup>

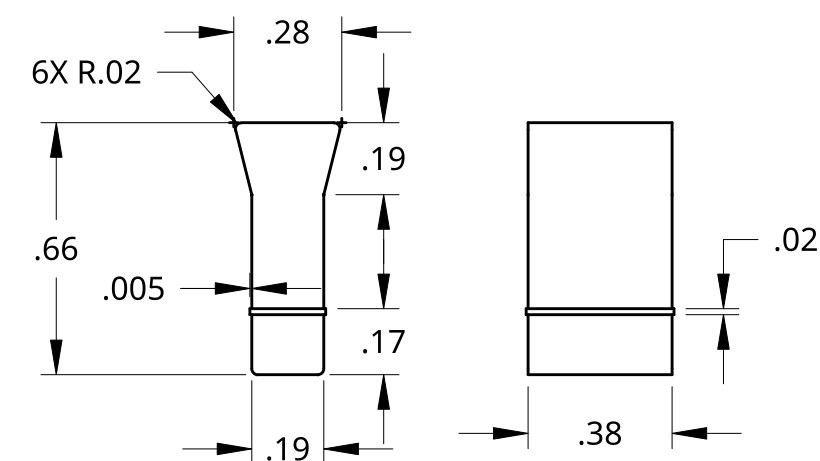

### PART 5: ROUND HEAD SCREW

MATERIAL: 1020 H.R.S.  
QUANTITY: 6  
VOLUME: 0.008942 in<sup>3</sup>  
SCALE: 4:1

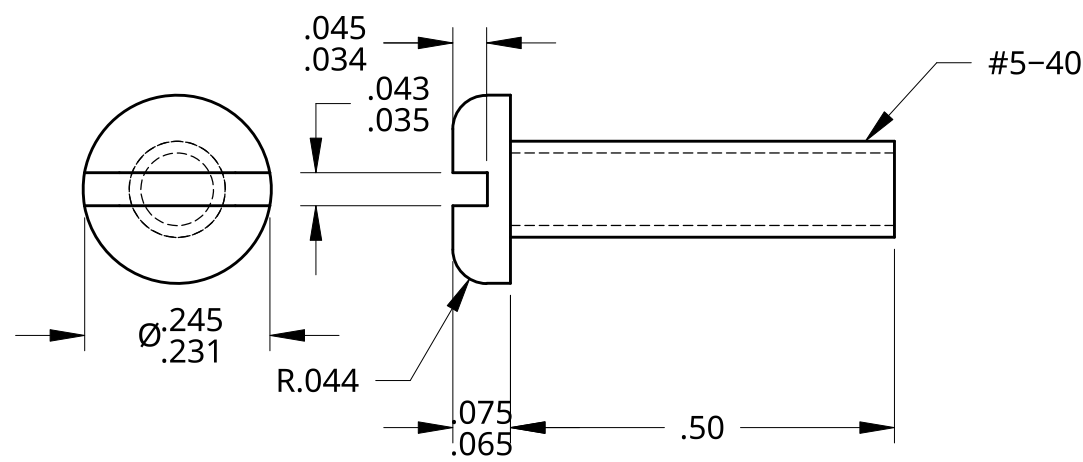

|  |                |          |        |                                  |            |
|--|----------------|----------|--------|----------------------------------|------------|
| UNLESS OTHERWISE SPECIFIED, DIMENSIONS ARE IN INCHES |                | NAME     | DATE   | TITLE<br><b>GLUE GUN DETAILS</b> |            |
| .XX = ±.01   | ANGULAR = ±°   | DRAWN    | 1379   |                                  | 04/18/2026 |
| .XXX = ±.005   | FRACTIONAL = ± | CHECKED  |        |                                  |            |
| .XXXX = ±.000-                                       |                | APPROVED |        |                                  |            |
| DO NOT SCALE DRAWING                                 |                |          |        | SIZE<br><b>C</b>                 |            |
| BREAK ALL SHARP EDGES AND REMOVE BURRS               |                |          |        | DWG NO.<br><b>26-WAH</b>         |            |
| THIRD ANGLE PROJECTION                               |                | MATERIAL | FINISH | REV.                             |            |
|  |                |          |        | SCALE<br><b>2:1</b>              |            |
|  |                |          |        | WEIGHT                           |            |
|  |                |          |        | SHEET<br><b>3 of 3</b>           |            |

4

3

2

1

D

C

B

A